



3-7002.090



C-7/02 English

WARNING!



SAFETY INSTRUCTIONS

1. Do not remove from pressurized lines.
2. Never install sensor without O-Rings.
3. Confirm chemical compatibility before use.
4. Do not exceed maximum temperature/pressure specifications.
5. Do not install/service without following mounting procedure.
6. Wear safety goggles and faceshield during installation/service.
7. Do not alter product construction.
8. Failure to follow safety instructions could result in severe personal injury.

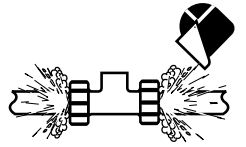

Description

The 3-7002 Vortex Flow Sensor uses vortex shedding technology as the primary method of determining the flow rate, and uses ultrasonic sensors to detect the vortices.

The only material in contact with the fluid is PVDF plastic. It is available in 3 in. (DN80) and 4 in. (DN100) sizes, and in Wafer and Flanged versions. Both ANSI and ISO bolt patterns are offered.

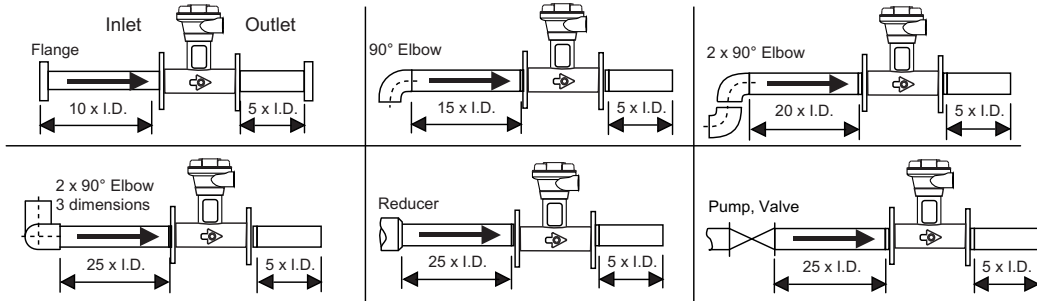

Location

- Six common piping systems are shown as guidelines to help you select the best location for the vortex flow sensor. Always maximize distance between sensors and pump sources.

Installation

- All mounting angles are acceptable in either horizontal or vertical pipe runs, with upward flow preferred in the case of vertical runs. Install the sensor with the arrow pointing in the direction of the flow.
- Pipe supports are recommended before and after the sensor to support the weight.
- * Install a "drip loop" or slope the conduit downward from the terminal block. Seal conduit entries with electrician's putty.
- Unused conduit ports and other openings where wiring is exposed must be properly sealed against moisture intrusion.

Reynold's Number

- To meet published specifications, a minimum Reynolds number of 16000 is required in a 3 in. (DN80) system, and a minimum value of 20000 is required in a 4 in. (DN 100) system.

A Reynold's Number is a dimensionless number used to determine the effects of viscosity, specific gravity, and velocity on flow sensor performance. As the viscosity of a fluid increases, the velocity (or flow rate) required to achieve accurate flow measurement also increases.

Use the formula to calculate the Reynolds number for your application.

Reynold's Number:

$$R_e = 3162.76 \times Q \times Sg / (\mu \times ID)$$

where: Q = Flow rate in GPM

Sg = Specific Gravity

μ = Dynamic Viscosity in Centipoise (cP)

ID = pipe inside diameter in inches

Backpressure Calculation

- Minimum downstream pipe backpressure levels are required to prevent cavitation within the sensor. The minimum back pressure is calculated by the following formula: $2.7 \times \Delta P + 1.3 \times P_o$ (ΔP = Pressure drop across sensor. P_o = Water saturation vapor pressure at operating temperature.)
1. Using Pressure Drop Graph, find ΔP by locating your maximum flow rate on specific sensor size line.
 2. Using the Water Saturation Vapor Pressures Chart, find P_o at operating temperature.
 3. Calculate minimum back pressure needed using formula.

Pressure Drop Graph

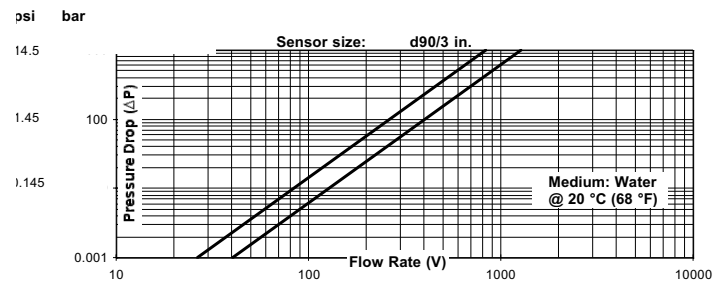

Water Saturation Vapor Pressures at Operating Temperatures

°C	-20	-10	0	10	20	25	30	40	50	65
°F	-4	14	32	50	68	77	86	104	122	149
Po (bar)	0.001	0.003	0.006	0.012	0.023	0.32	0.042	0.074	0.123	0.25
Po (psia)	0.014	0.038	0.088	0.178	0.338	4.58	0.614	1.067	1.784	3.626

Installation

- Proper alignment of the sensor with gaskets and flanges is necessary to assure a uniform flow profile through the sensor.
- Space flanges in the piping system according to the length of the vortex flow sensor body.
- Observe torque recommendations.
- Mounting hardware, gaskets and piping system components (shown with broken lines in the diagrams below) are not furnished with the vortex flow sensors.
- For flange versions: Bolt length approximations shown in the table above include two flange adapters, two flange rings and a gasket, all typical of +GF+ SYGEF-PVDF piping system components, plus nuts and washers.
- For wafer versions: If the application requires operation outside the range 15 to 35° C (59 to 95° F), then the accessory Spring Kit (3-7002.391) is necessary to relieve the forces due to thermal expansion of PVDF material and/or to prevent leakage during cooling. Bolt length approximations shown in the table above include sensor length, width dimensions for two each flange adapters, flange rings and gaskets, all typical of +GF+ SYGEF-PVDF piping system components, plus nuts and washers. If the accessory Spring Kit will be used, bolt length requirements increase by 60.0 mm (2.5 inches.)



- Do not exceed 70 °C media temperature
- Do not exceed torque specifications.

Flanged Vortex Sensor

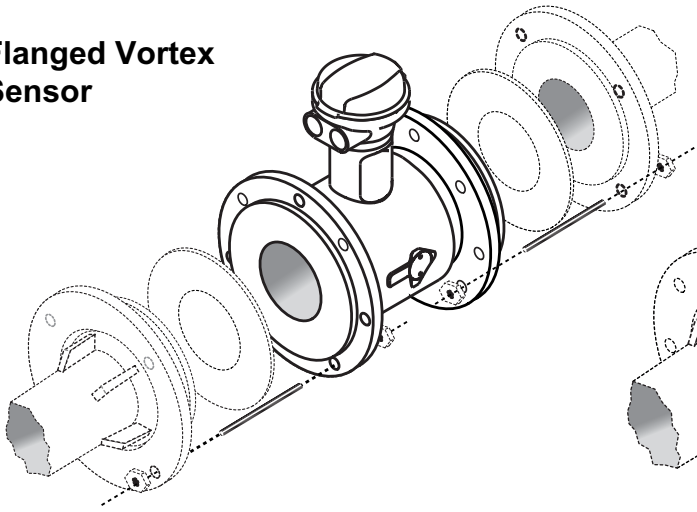

Wafer Vortex Sensor

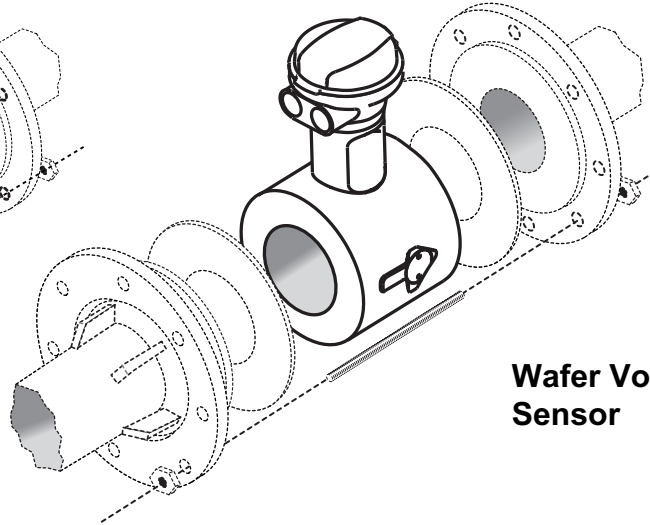

Sensor	Config.	# of Bolts	Bolt Diameter	Approximate Bolt Length	Required Torque
3" Flange	ISO	16	M16 (5/8" - 11)	70 mm (2.75")	40 ± 5 N•m (30 ± 4 lbf•ft)
3" Flange	ANSI	8	M16 (5/8" - 11)	70 mm (2.75")	40 ± 5 N•m (30 ± 4 lbf•ft)
4" Flange	ISO	16	M16 (5/8" - 11)	80 mm (3.00")	45 ± 5 N•m (33 ± 4 lbf•ft)
4" Flange	ANSI	16	M16 (5/8" - 11)	80 mm (3.00")	45 ± 5 N•m (33 ± 4 lbf•ft)
3" Wafer	ISO	8	M16 (5/8" - 11)	180 mm (7.50")	25 N•m (18.5 lbf•ft)
3" Wafer	ANSI	4	M16 (5/8" - 11)	180 mm (7.50")	25 N•m (18.5 lbf•ft)
4" Wafer	ISO	8	M16 (5/8" - 11)	220 mm (8.50")	30 N•m (22 lbf•ft)
4" Wafer	ANSI	8	M16 (5/8" - 11)	220 mm (8.50")	30 N•m (22 lbf•ft)

Tighten the flange bolts in the appropriate sequence.

Tightened each bolt to 50% of the specification, repeat the pattern to 80%, then repeat again to the specified torque.

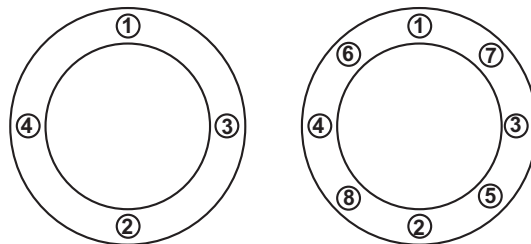

Wiring for Frequency Output

The open-collector frequency output requires a three-wire connection between the sensor and the monitoring device.

To wire the vortex sensor frequency output to remote equipment:

- Cable with single twisted-pair plus shield recommended.
- Maximum cable length 200 ft.
- Install cable through a conduit port and connect as shown to the terminal block inside the vortex sensor cap.
- Open collector voltage is supplied by +GF+ SIGNET instruments.
- Use the 2535/2536 input card setting when wiring to the +GF+ SIGNET 9010 Inteltek-Pro Flow Controller

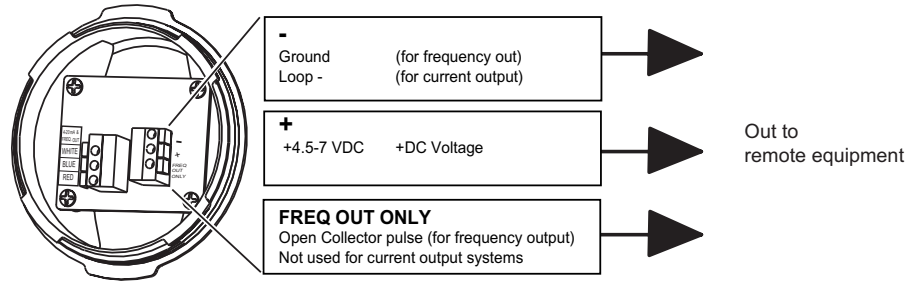

To wire the vortex sensor frequency output to a Signet 8550 Integral transmitter:

- Disconnect the sensor wires completely from the vortex sensor cap. The cap will not be used.
- Connect the Vortex sensor to the 8550 as shown.

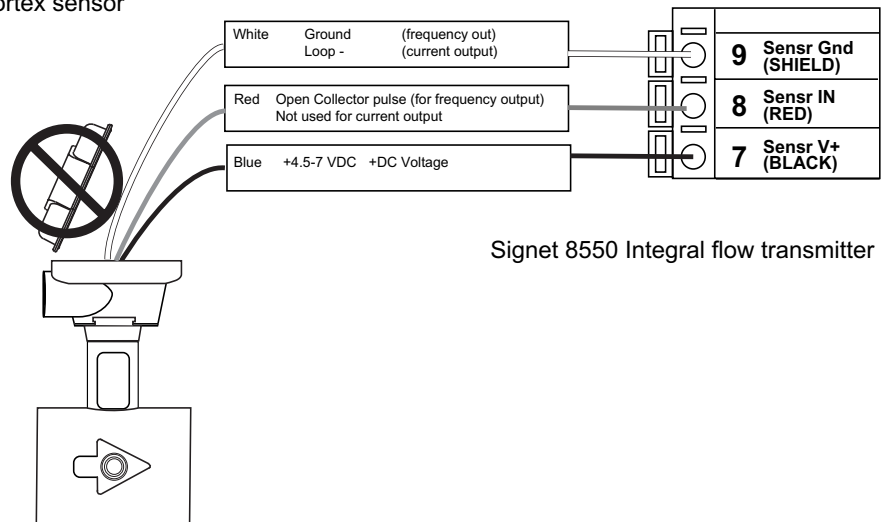

Calibration Data: Frequency Output

Use the following K-factor data to program a flow meter which accepts the open collector frequency signal from the vortex flow sensor. The K-factor is the number of pulses generated by each gallon (or liter) of fluid that passes through the sensor.

K-Factors for 3-7002 Vortex Sensor		
Flow Units	d90/DN80 (i.d.≈ 3 inch)	d110/DN100 (i.d.≈ 4 inch)
U.S. Gallons	18.55	9.84
Liters	4.90	2.60
Frequency out at 4 m/s	93 Hz	76 Hz

Wiring for Current Output

The 4-20 mA current output selection requires a two-wire loop connection between the sensor and monitoring device.

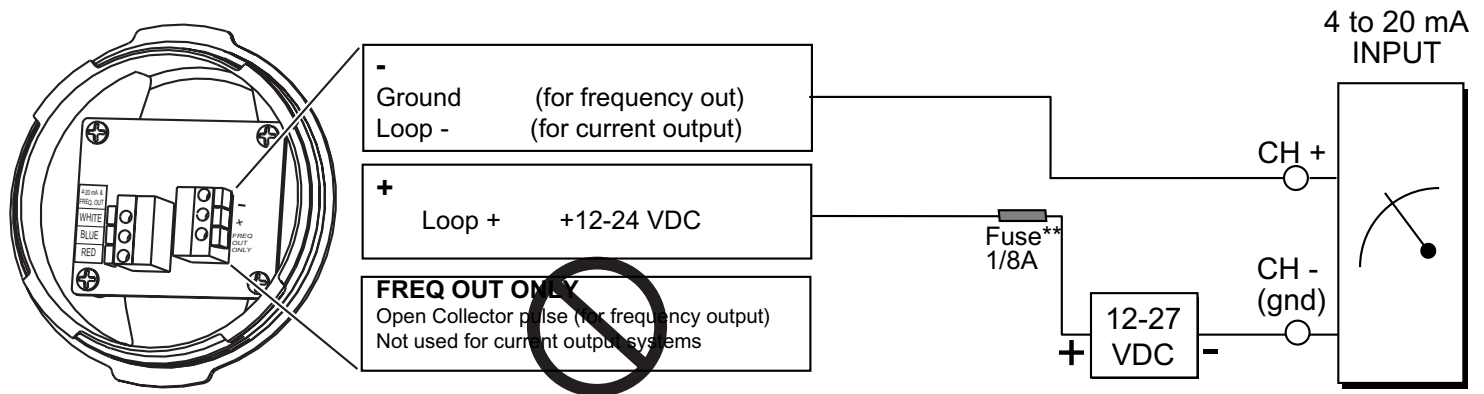

Calibration - Current Output

The current output from the 3-7002 is factory-calibrated for full scale operation (4-20 mA = 0-4 m/s).

Since the sensor is limited to a minimum of 0.2 m/s, the current output is held at 4 mA when flow is less than 0.2 m/s, (or 0.66 ft/s), and increases to 20 mA at the maximum flow velocity (4.0 m/s, or 13.12 ft/s).

The charts on page 5 show the relationship between the fluid velocity, the actual flow rate (in GPM and LPM) and the current output. You can also use the following formula to calculate the current output at any specific flow velocity.

$$\left(\frac{\text{Fluid velocity in pipe}}{\text{Max sensor velocity}} \times 16 \right) + 4 = \text{current output (mA)}$$

Example 1: In a pipe with a flow velocity of 2 m/s, what is the correct current output?:

$$\left(\frac{2 \text{ (m/s)}}{4 \text{ (m/s)}} \times 16 \right) + 4 = \mathbf{12.0 \text{ mA}}$$

Example 2: In a 4 in. pipe what should the current output be when the flow rate is 200 gpm?:

$$\left(\frac{200 \text{ gpm}}{458.65 \text{ gpm}} \times 16 \right) + 4 = \mathbf{10.97 \text{ mA}}$$

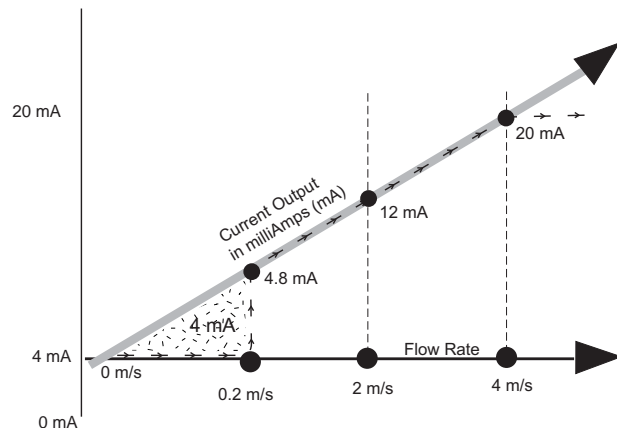

Velocity-Flow Rate-Current output Chart

DN 80 Vortex Sensor (3 in.)						
At this velocity:		the flow rate will be:		and the current output will be:	and the frequency output will be:*	
m/s	ft/s	lpm	gpm			
0	0	0	0.00	4.00 mA	0 Hz	Below 0.2 m/s, the output is 4.0 mA
0.1	0.33	28.64	7.57	4.00 mA	≈ 1.9 Hz	
0.2	0.66	57.28	15.13	4.80 mA	4.6 Hz	
0.5	1.64	143.2	37.83	6.00 mA	12 Hz	
1	3.28	286.4	75.67	8.00 mA	23 Hz	
1.5	4.92	429.6	113.50	10 mA	35 Hz	
2	6.56	572.8	151.33	12.00 mA	47 Hz	
2.5	8.2	716	189.17	14.00 mA	58 Hz	
3	9.84	859.2	227.00	16.00 mA	70 Hz	
3.5	11.48	1002.4	264.83	18.00 mA	82 Hz	
4	13.12	1145.6	302.67	20.00 mA	93 Hz	
Beyond 4 m/s the current output is 20.00 mA						

DN 100 Vortex Sensor (4 in.)						
At this velocity:		the flow rate will be:		and the current output will be:	and the frequency output will be:*	
m/s	ft/s	lpm	gpm			
0	0	0	0.00	4.00 mA	0 Hz	Below 0.2 m/s, the output is 4.0 mA
0.1	0.33	43.4	11.47	4.00 mA	≈ 1.9 Hz	
0.2	0.66	86.8	22.93	4.80 mA	3.8 Hz	
0.5	1.64	217	57.33	6.00 mA	9.4 Hz	
1	3.28	434	114.66	8.00 mA	19 Hz	
1.5	4.92	651	171.99	10.00 mA	28 Hz	
2	6.56	868	229.33	12.00 mA	38 Hz	
2.5	8.2	1085	286.66	14.00 mA	47 Hz	
3	9.84	1302	343.99	16.00 mA	56 Hz	
3.5	11.48	1519	401.32	18.00 mA	66 Hz	
4	13.12	1736	458.65	20.00 mA	76 Hz	
Beyond 4 m/s the current output is 20.00 mA						

* Standard output is factory fixed at 4 to 20 mA = 0.2 to 4 m/sec.
Custom ranges can be provided by the factory.

Technical Data

Wetted materials

- Sensor body: PVDF

Pipe size

- d90/DN80 (3 in.) and d110/DN100 (4 in.)

Linear Flow range

Turn-down ratio: 20:1

- d90/DN80 (3 in.):
Reynolds \geq 16000: 0.2 to 4 m/s (0.66 to 13 ft/s)
- d110/DN100 (4 in.):
Reynolds \geq 20000: 0.2 to 4 m/s (0.66 to 13 ft/s)

NOTE: Below these velocity ranges, Vortex output is non-linear.

Electronics module enclosure

- Rating: NEMA 4X/IP65
- Material: Valox®
[Polybutylene Terephthalate (PBT) resin]

Weight:

Wafer	3 in./DN80:	4.5 lb./2.0 kg
	4 in./DN 100:	7.0 lb./3.2 kg
Flange:	3 in./DN80:	11.0 lb./5.0 kg
	4 in./DN100:	16.0 lb./7.3 kg

Electrical

- Accuracy: \pm 1% of reading
- Repeatability: \pm 0.25% of reading
- Response time: 1 s., first order
5 s. settled to 1% of rate
- Reverse polarity protection
- Open Collector output:
 - NPN transistor, 10 mA max sink, 30 VDC max pull-up voltage, 0 to 100 Hz, 50% duty cycle, non-isolated.
< 100 hz at maximum range.
 - Power requirement:
4.5 to 7 VDC, regulated, 10 mA maximum
- Current output:
 - factory-set; 4 to 20 mA = 0 to 4 m/s (0 to 13 ft/s)
(Custom ranges available from factory)
 - Loop impedance: 1 Ω maximum at 12 VDC
600 Ω maximum at 24 VDC
 - Resolution: \approx 2.5 μ A
 - Power requirement:
12 to 24 VDC, regulated, 20 mA maximum

Environmental

Rating: NEMA 4X/IP65

Maximum Media Pressure/Temperature

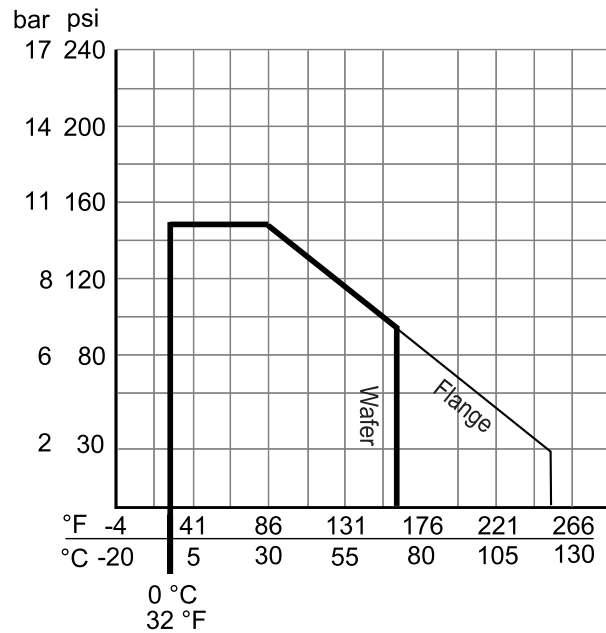

Wafer Vortex Sensor: 10 bar @ 30 °C, 6.5 bar @ 70 °C
(145 psi @ 86 °F, 94 psi @ 158 °F)

Flange Vortex Sensor: 10 bar @ 30 °C, 2 bar @ 120 °C
(145 psi @ 86 °F, 30 psi @ 248 °F)

- Ambient temp.: 0 to 70 °C (32 to 158 °F)
- Storage temp.: -15 to 80 °C (5 to 176 °F)
- Relative humidity: 0 to 95%, non-condensing
- Vibration resistance: At least 1g in every axis up to 500 Hz.
(The ultrasonic pickup is unaffected by normal piping system vibrations.)

Standards and Approvals

- Manufactured under ISO 9001 and ISO 14001
- CE

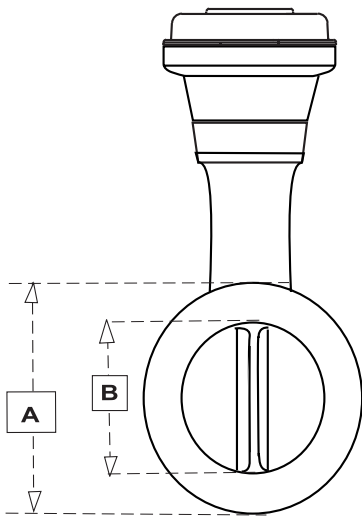

Wafer Vortex Sensor dimensions

Size	A		B		C		D	
	mm	inch	mm	inch	mm	inch	mm	inch
DN80	133.1	5.24	78.0	3.07	108.0	4.25	251.7	9.91
DN100	158.0	6.22	96.0	3.78	127.0	5.00	277.1	10.91

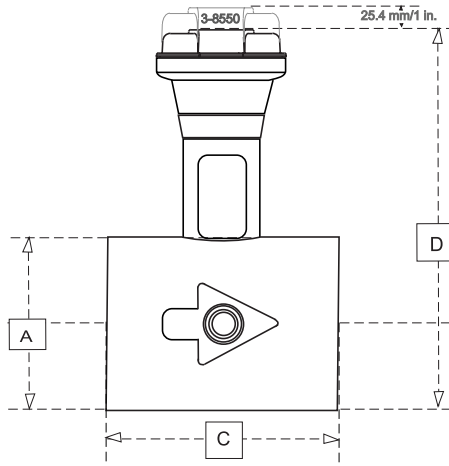

Flange Vortex Sensor dimensions

Size	A		B		C		D	
	mm	inch	mm	inch	mm	inch	mm	inch
DN80	196.9	7.75	78.0	3.07	199.9	7.87	287.0	11.3
DN100	228.6	9.00	96.0	3.78	249.9	9.84	322.6	12.7

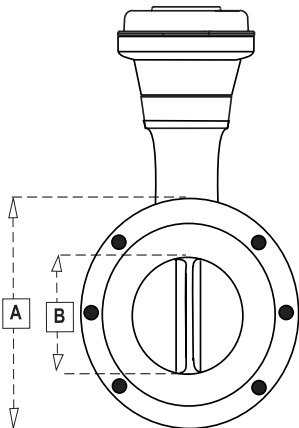
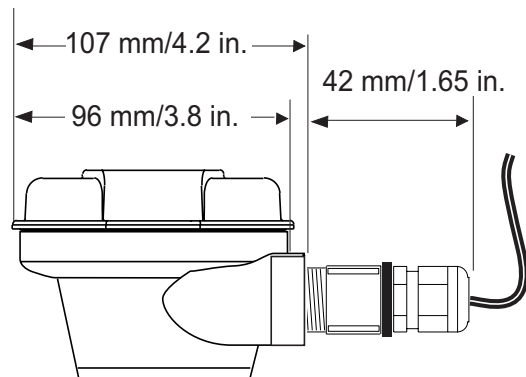
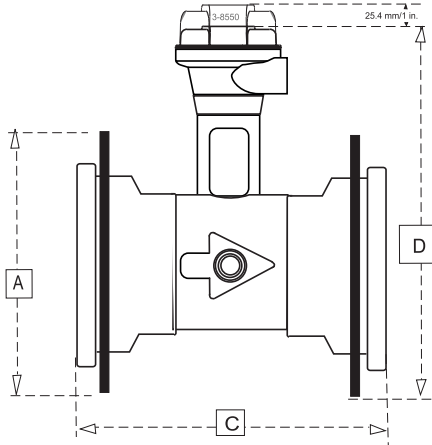

Ordering Information

3-7002 -

Material

2	HP-PVDF
3	PVDF

Size

A	3 in. d90/DN80
B	4 in. d110/DN100

+GF+ SIGNET 7002 Vortex Flow Sensors

Part Number	Code	Description
3-7002-2AF	159 000 657	High-Purity 3" (d90/DN80) Flange, ANSI
3-7002-2AFI	159 000 658	High-Purity 3" (d90/DN80) Flange, ISO
3-7002-2AW	159 000 661	High-Purity 3" (d90/DN80) Wafer
3-7002-2BF	159 000 662	High-Purity 4" (d110/DN100) Flange, ANSI
3-7002-2BFI	159 000 663	High-Purity 4" (d110/DN100) Flange, ISO
3-7002-2BW	159 000 666	High-Purity 4" (d110/DN100) Wafer
3-7002-3AF	159 000 667	PVDF 3" (d90/DN80) Flange, ANSI
3-7002-3AFI	159 000 668	PVDF 3" (d90/DN80) Flange, ISO
3-7002-3AW	159 000 671	PVDF 3" (d90/DN80) Wafer
3-7002-3BF	159 000 672	PVDF 4" (d110/DN100) Flange, ANSI
3-7002-3BFI	159 000 673	PVDF 4" (d110/DN100) Flange, ISO
3-7002-3BW	159 000 676	PVDF 4" (d110/DN100) Wafer

Configuration

W	Wafer
F	Flange, ANSI
FI	Flange, ISO

Accessories

Part Number	Code	Description
3-8550-1	159 000 210	Flow Transmitter for Field Mount
3-8550-2	159 000 212	Flow Transmitter with 2 Relays for Field Mount
3-8550-3	159 000 214	2-Channel Flow Transmitter for Field Mount
3-8050	159 000 184	Universal Adapter Kit
3-0000.393	159 000 618	Liquid Tight Connector Kit with PG 13.5 to NPT Adapter
3-7002.391	159 000 692	Spring Kit (includes four (4) springs)

+GF+ SIGNET

Signet Scientific Company, 3401 Aerojet Avenue, El Monte, CA 91731-2882 U.S.A. • Tel. (626) 571-2770 • Fax (626) 573-2057
 For Worldwide Sales and Service, visit our website: www.gfsignet.com • Or call (in the U.S.): (800) 854-4090

