

**+GF+ SIGNET**

**2850 DryLoc™ Conductivity/Resistivity Sensor Electronics**



3-2850.090



D (3/03) English

**Table of contents**

1. Description
2. Specifications
3. Installation
4. Wiring
5. 4 to 20 mA ranges
6. Calibration
7. Maintenance and Troubleshooting
8. Ordering information

**WARNING!**



**SAFETY INSTRUCTIONS**

1. Depressurize and vent system prior to installation or removal.
2. Confirm chemical compatibility before use.
3. Do not exceed maximum temperature/pressure specifications.
4. Wear safety goggles or faceshield during installation/service.
5. Do not alter product construction.
6. When using chemicals or solvents care should be taken and appropriate eye, face, hand, body, and/or respiratory protection should be used.



**1. Description**

+GF+ SIGNET 2850 Conductivity/Resistivity Sensors provide two-wire 4 to 20 mA output, or S<sup>3</sup>L™ digital interface, depending upon the applied power to the unit.

In 4 to 20 mA output mode eight ranges for each electrode cell constant, plus the ability to invert each range, are selectable by the user in the field.

NEMA 4X Junction Boxes are integral parts of in-line versions and are available as accessories for submersible versions. With the optional EasyCal feature, the devices automatically recognize standard conductivity test solution values for simple field calibration.

**System Overview**

- a) 2850-1, -2 Sensor Electronics
- b) DryLoc™ electrode connector
- c) 2839-2842 DryLoc™ Conductivity/Resistivity Electrode (sold separately)
- d) S<sup>3</sup>L™ or 4-20 mA Output (field selectable)
- e) 2850-3, -4 Sensor Electronics
- f) Extension Pipe (customer supplied)
- g) 8052-1CR, -2CR Junction Box (sold separately)

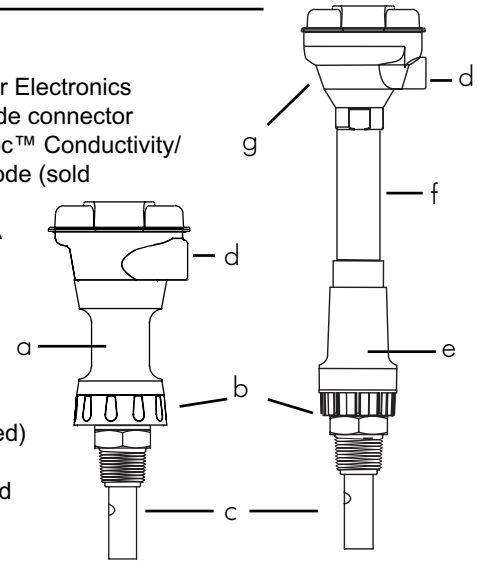

**2. Specifications**

**2.1 General**

Compatible Electrodes: 2839-2842 DryLoc™ CR Electrodes  
Materials and Shipping Weight:

- 2850-1, -2 (in-line): PBT; 0.75 kg (1.75 lb.)
- 2850-3, -4 (submersible): CPVC; 0.75 kg (1.75 lb.)

Temperature Compensation: Automatic

Optional EasyCal:

Automatic recognition of the following conductivity values:

- 146.93 μS, 1408.8 μS, 12856 μS  
(Test solutions Per ASTM D1125-95)
- 10 μS, 100 μS, 200 μS, 500 μS, 1000 μS, 5000 μS, 10,000 μS, 50,000 μS, 100,000 μS (Standard test solutions available from VWR Scientific)
- Cable (2850-3, 2850-4): 4.5 m/15 ft., 5-conductor shielded, 22 AWG, black/red/white/green/brown/shield

**Electrical**

Power: 12 to 24 VDC for 4 to 20 mA output  
5 VDC +/-5% regulated, 2 mA max. for S<sup>3</sup>L output

**Note:** Applied power determines output mode (S<sup>3</sup>L™ or 4-20 mA)  
Reverse polarity and short circuit protected

S<sup>3</sup>L™ Output: Serial ASCII, TTL level 9600 bps

- Accuracy: Conductivity: 2% of reading  
Temperature: ±0.5°C
- Resolution: Conductivity: 0.1% of reading  
Temperature: <0.07°C
- Update Rate: <600 ms

Available data via S<sup>3</sup>L Output:

- Raw conductivity
- Calibrated conductivity
- Calibrated temperature-compensated conductivity
- Temperature

Error Indication: Open input and out of range diagnostics for conductivity and temperature.

Current Output:

- 2850-1, -2 (in-line): Field-selectable ranges
- 2850-3, -4 (submersible): Full-scale fixed 4 to 20 mA, dependent upon cell constant of electrode as follows:  
0.01 cell (2839-2X): 4 to 20 mA = 0 to 100 μS  
0.10 cell (2840-2X): 4 to 20 mA = 0 to 1000 μS  
1.0 cell (2841-2X): 4 to 20 mA = 0 to 10,000 μS  
10.0 cell (2842-2X): 4 to 20 mA = 0 to 200,000 μS

Use 8050-XCR and 8052-XCR accessory J-Boxes for field-selectable ranges.

- Max. Loop Resistance: 50Ω @ 12 VDC  
325Ω @ 18 VDC  
600Ω @ 24 VDC
- Accuracy: ±2% of full scale
- Resolution: 7 μA
- Update Rate: <600 ms
- Error Indication: 22 mA

## Environmental

Enclosure Rating:

- 2850-1, -2 (in-line): NEMA 4X/IP65 with electrode connected
- 2850-3,-4 (submersible): NEMA 6P/IP68 with electrode and watertight conduit and/or extension pipe connected
- Storage Temp.: -20°C to 85°C (-4°F to 185°F)
- Operating Temp.: -10°C to 85°C (14°F to 185°F)
- Relative Humidity: 0 to 95%, non-condensing (without electrode connected)

## Standards & Approvals

- CE
- Immunity: EN61326-1
- Emissions: EN55011 Class A
- Manufactured under ISO 9001 and ISO 14001

2850 Electronics Operating Range:

- 0.01 cell (2839-2X): 0.010 to 100  $\mu$ S
- 0.10 cell (2840-2X): 1 to 1000  $\mu$ S
- 1.0 cell (2841-2X): 10 to 10,000  $\mu$ S
- 10.0 cell (2842-2X): 100 to 200,000  $\mu$ S
- Temperature: -10°C to 85°C (14°F to 185°F)

## 2.2 Electrodes

Compatibility:

+GF+ SIGNET 2850 Conductivity/Resistivity Sensor (see data sheets for more information)

Accuracy:

$\pm$ 2% of cell constant value (standard)  
Cell constants can be traceable to NIST and certified to within  $\pm$ 1% of value (contact factory)

Temperature element:

PT-1000

Temp. response,  $\tau$ :

5 sec. (0.01 cell), 10 sec. (0.10 cell),  
20 sec. (1.0 cell), 30 sec. (10.0 cell)

Temp. accuracy:

$\pm$ 0.5°C

Process Connection:

(PEEK™)  
-2 versions: 3/4 in. NPT  
-2D versions: ISO 7-R<sup>3/4</sup>

## Wetted Materials

- DryLoc™ connection to 2850: CPVC
- Internal O-ring (2841 and 2842): FPM
- Insulator material: PEEK™
- Electrode material: 316L SS
- Shipping Weight:
  - 2839: 0.34 kg (0.74 lb)
  - 2840, 2841, 2842: 0.30 kg (0.66 lb)

## Standards and Approvals

- CE
- Manufactured under ISO 9001 and ISO 14001

## Operating Range Chart

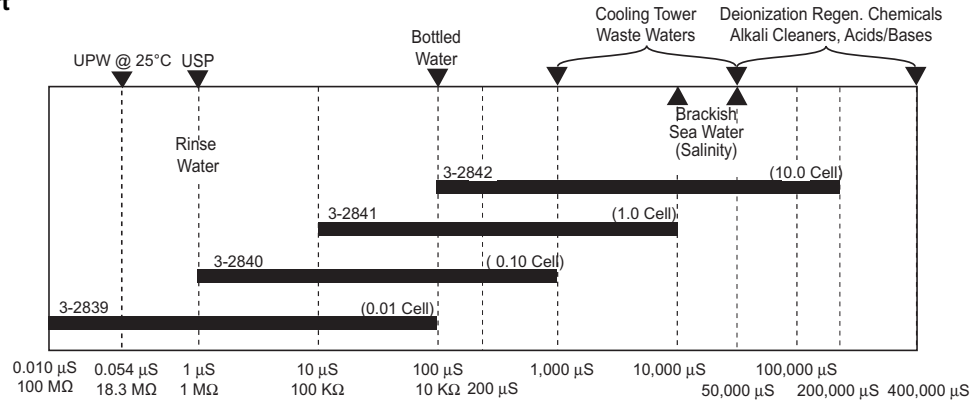

## 2.3 Dimensions

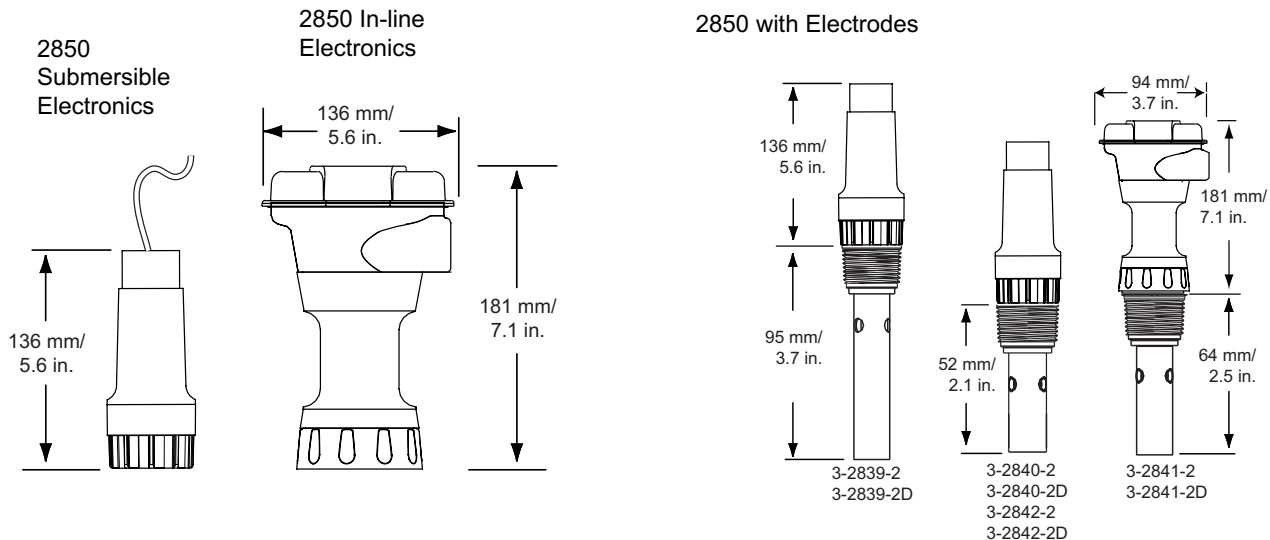

### 3. Installation

#### 3.1 In-Line sensor assembly

1. Unlock the ring on the base of the 2850 (The ring is unlocked when the lines on the ring and body of the 2850 are not aligned.)
2. Place 2850 onto top of electrode and turn until the DryLoc™ connector is seated.
3. Lock the connection by turning the ring 1/4 turn CCW. (The ring is locked when the line on the ring and the line on the body of the 2850 are aligned.)

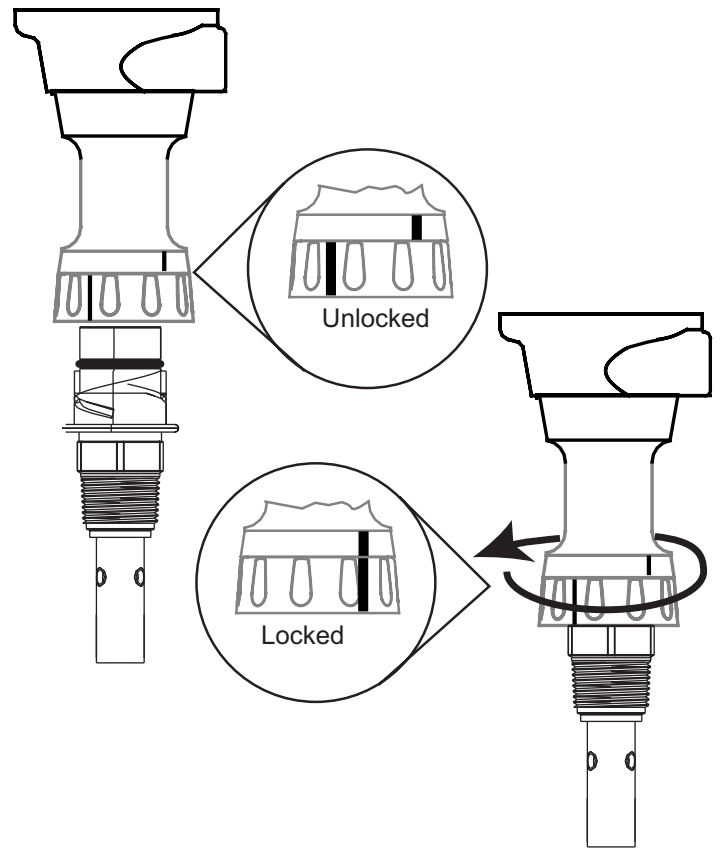

#### In-Line Sensor and Electrode Removal

- **To remove electronics assembly only:**  
Turn locking ring 1/4 turn CW and lift electronics away from electrode.
- **To remove electrode from the pipe:**  
Remove electronics assembly, then unthread electrode from fitting.

**Note:**

Keep the electrical interconnection between electrode and sensor electronics dry and clean at all times.

#### 3.2 In-Line Installation

DryLoc™ Conductivity/Resistivity electrodes can be installed into standard 3/4 in. NPT (or ISO 7-R3/4) fittings.

The preferred installation for in-line applications directs flow straight into the electrode. This configuration reduces the probability of entrapped air bubbles, and provides the best continuous sampling of the fluid content.

If the electrode is mounted vertically in a tee, do not recess the orifices inside the tee. Mounting upside down may help prevent air entrapment.

An oversized tee or flow cell may be helpful for inline installations.

At least 4 threads (ANSI B1.20.1) must be engaged to meet pressure rating per published specifications.

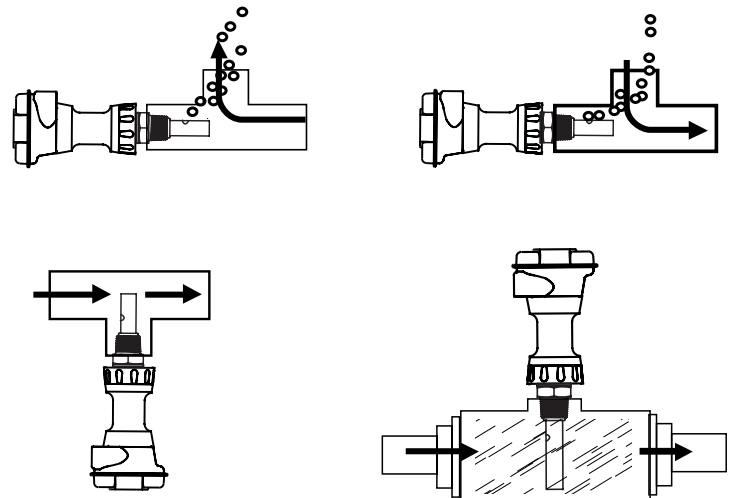

**CAUTION!**



- Do not remove the electrode from a pressurized pipe.
- Wear appropriate protective clothing when working with the system.
- Wetted materials include 316L stainless steel, PEEK™ (FPM O-ring inside 2841, 2842).
- Check for chemical compatibility before installing electrode.

### 3.3 Submersible Sensor Assembly

1. Remove retaining nut from 2850.
2. Insert electrode into 2850 and turn until the DryLoc™ connector is seated. A light coat of non-petroleum based lubricant on the O-ring will ease installation.
3. Place retaining nut over bottom of electrode and thread onto 2850 until secure.
4. Feed cable into watertight conduit. Apply thread sealant to the conduit before threading conduit into the 2850. Avoid twisting the cable.
5. Secure cable with conduit or cable gland.
6. For additional defense against possible accumulation of moisture at the back seal area of the electrode, fill the lower 3-4 inches (75-100 mm) of conduit or extension pipe with a flexible sealant such as silicone.

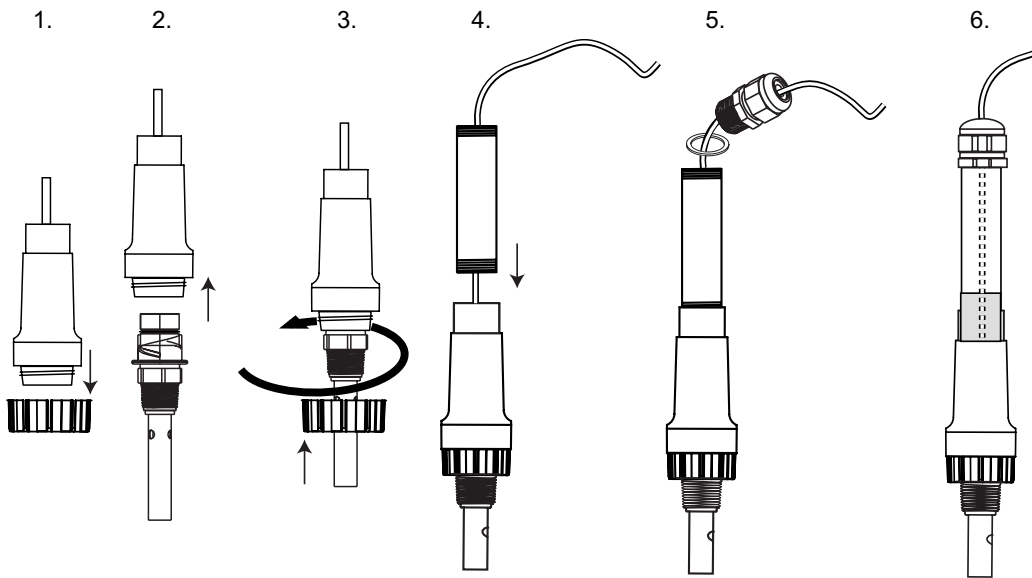

### 3.4 Submersible Installation



#### CAUTION!

- Wear appropriate protective clothing when working with the piping system.
- Wetted materials include CPVC, 316L stainless steel, PEEK™ (FPM O-ring inside 2841, 2842).
- Check for chemical compatibility before installing electrode.

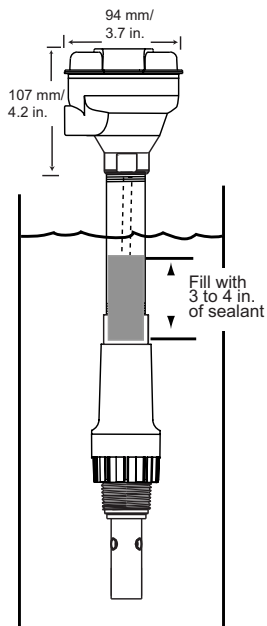

The 8052-xCR NPT Mount Junction box connects to 3/4 in. pipe or conduit and provides convenient wiring termination.

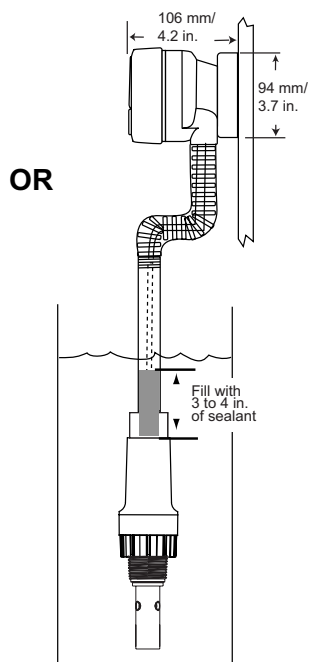

The 8050-xCR Universal Mount junction box mounts flat onto a wall or can be strapped to a post or pipe and provides convenient wiring termination.

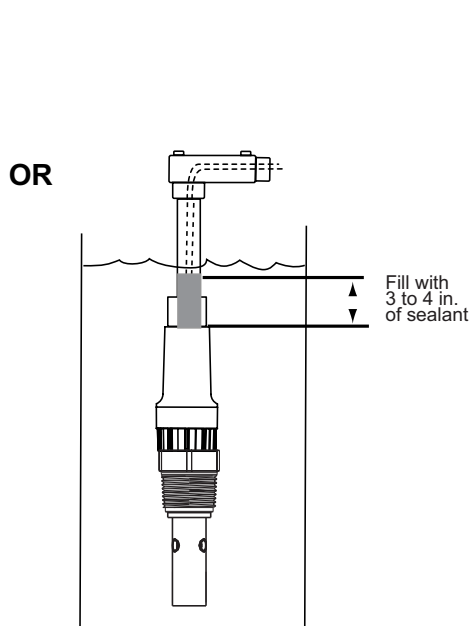

Use standard installation hardware to connect the submersible 2850-3 or -4 directly to external equipment.

In aerated vessels install the electrode in a stillwell to prevent air from being trapped inside the electrode.

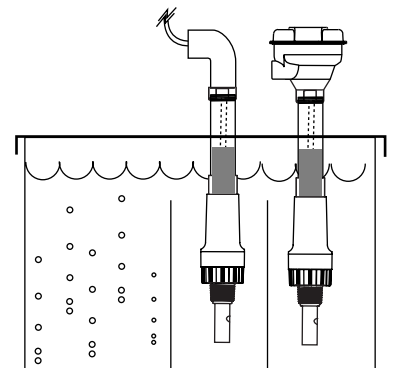

**Note:** Maximum wire length between 2850-x and 805x-xCR J-boxes is 4.5m (15 ft).

## 4. Wiring

### 4.1 Wiring Direct (No Junction Box)

- The 2850 automatically recognizes the electrode cell constant when power is applied.
- When 5 VDC is applied to the 2850, the S<sup>3</sup>L™ serial data output is automatically enabled.
- When 12 to 24 VDC is applied to the 2850, the 4 to 20 mA output is automatically enabled.
- The 2850 cannot output S<sup>3</sup>L™ and 4-20 mA signals simultaneously.
- Remove approximately 10 mm (0.4 in.) of insulation and tin each conductor before inserting into connectors.

#### S<sup>3</sup>L™ with no Junction Box

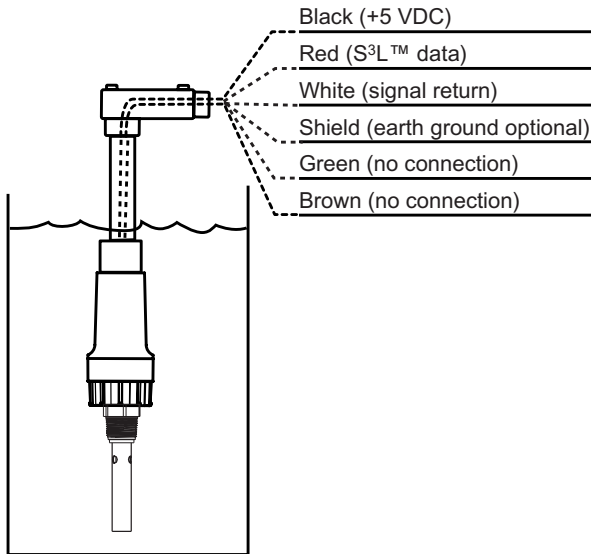

- Connect the 2850 cable directly to S<sup>3</sup>L™ I/O terminals.
- **8900 users:** When wiring the 2850 directly to the 8900, set the CALIBRATE menu to "perform calibration at INSTRUMENT"

#### 4-20 mA output with no Junction Box

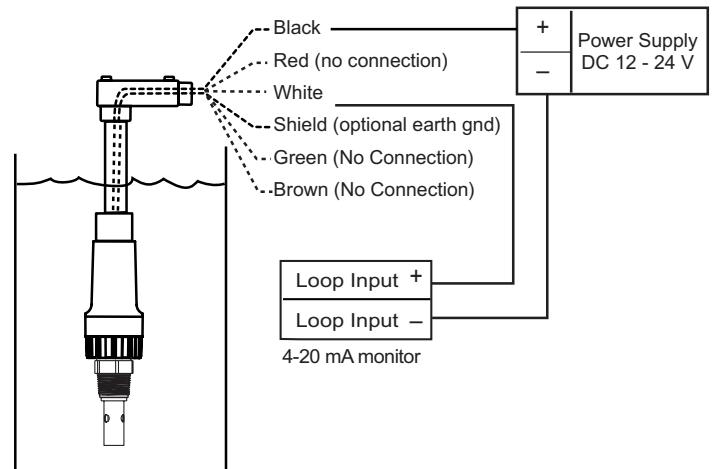

- Connect the 2850 cable directly to a Loop device as shown.
- This configuration does not provide any calibration capability within the 2850 system. Calibration must be performed at the external equipment.

### 4.2 Wiring to Junction Box

#### S<sup>3</sup>L™ output with Junction Box

- **8900 users:** To calibrate the 2850 using EasyCal, set the 8900 CALIBRATE menu to "Perform calibration at SENSOR".

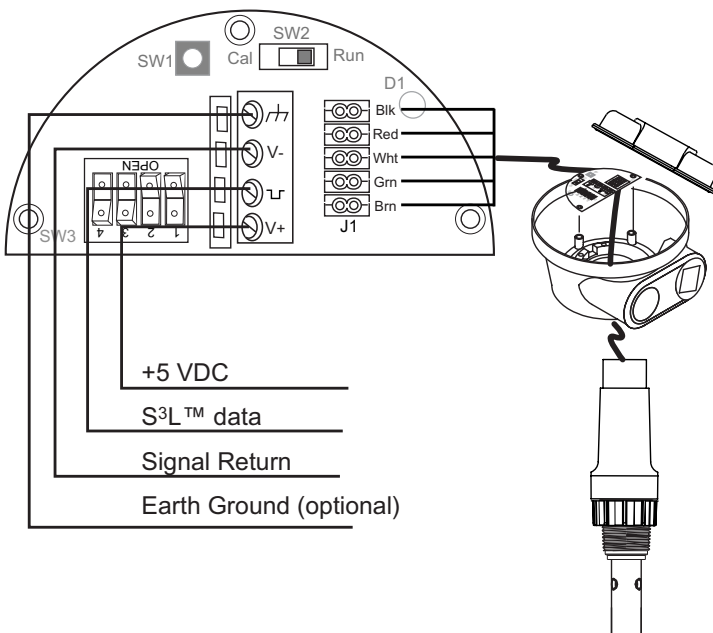

#### 4-20 mA output with Junction Box

- Junction boxes with Range selection switches (8050-1CR, 8050-2CR, 8052-1CR, 8052-2CR) must be located within 4.5m (15 ft) of the 2850.

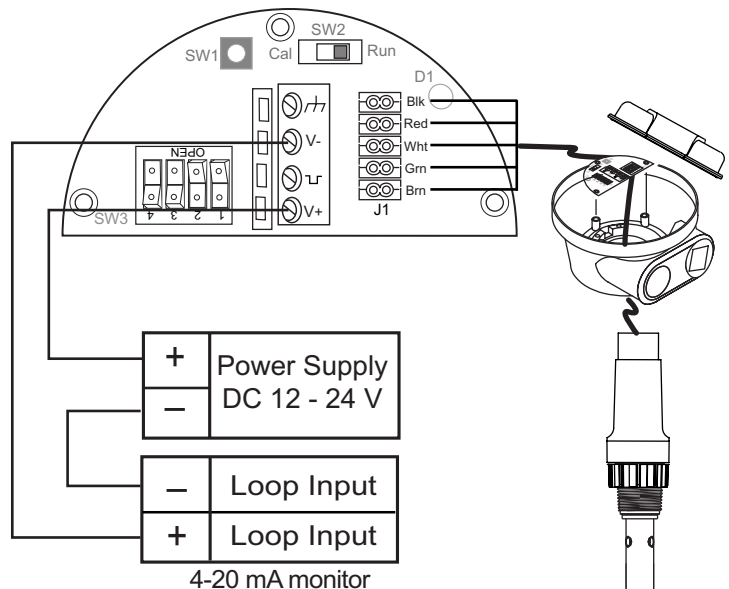

## 5. Range Selection for 4 to 20mA Output

- The 2850 automatically recognizes the electrode cell constant when power is applied.
- The 4-20 mA output range is field selectable when any junction box with CR Range or EasyCal installed.
- The Range selection switches (SW3) provide eight range selections for each cell constant. Each range can be inverted, making a total of 16 range options.
- Select a range from the table below and set SW3 as indicated.

A switch is OPEN when it is depressed on the OPEN side.  
Switches 4 and 3 are OPEN.

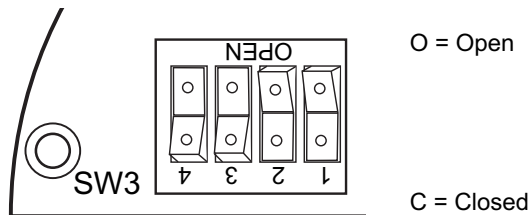

A switch is CLOSED when it is depressed on the NUMBER side.  
Switches 2 and 1 are CLOSED.

### 5.1 Selectable ranges for 4-20 mA output operation

#### Example (refer to shaded selections of chart):

- The electrode installed is the 3-2840-2X, 0.10 cell constant.
- You desire the output to be 4-20 mA = 0-100  $\mu$ S.
- Set SW3 switches to O-O-C-C. (switch sequence 4-3-2-1)
- To invert (4-20 mA = 100-0  $\mu$ S), Close switch #4.

SW3 Switch setting				0.01 Cell	0.10 Cell	1.0 Cell	10.0 Cell
#4	#3	#2	#1	Resistivity Ranges in <b>BOLD</b>			
O	C	C	C	<b>10 to 20 M<math>\Omega</math></b>	0 to 2 $\mu$ S	0 to 20 $\mu$ S	0 to 200 $\mu$ S
C	C	C	C	<b>20 to 10 M<math>\Omega</math></b>	2 to 0 $\mu$ S	20 to $\mu$ S	200 to 0 $\mu$ S
O	C	C	O	<b>2 to 10 M<math>\Omega</math></b>	0 to 5 $\mu$ S	0 to 50 $\mu$ S	0 to 500 $\mu$ S
C	C	C	O	<b>10 to 2 M<math>\Omega</math></b>	5 to 0 $\mu$ S	50 to 0 $\mu$ S	500 to 0 $\mu$ S
O	C	O	C	<b>0 to 2 M<math>\Omega</math></b>	0 to 10 $\mu$ S	0 to 100 $\mu$ S	0 to 1 000 $\mu$ S
C	C	O	C	<b>2 to 0 M<math>\Omega</math></b>	10 to 0 $\mu$ S	100 to 0 $\mu$ S	1 000 to 0 $\mu$ S
O	C	O	O	0 to 1 $\mu$ S	0 to 50 $\mu$ S	0 to 500 $\mu$ S	0 to 5 000 $\mu$ S
C	C	O	O	1 to 0 $\mu$ S	50 to 0 $\mu$ S	500 to 0 $\mu$ S	5 000 to 0 $\mu$ S
<b>O</b>	<b>O</b>	<b>C</b>	<b>C</b>	0 to 5 $\mu$ S	<b>0 to 100 <math>\mu</math>S</b>	0 to 1 000 $\mu$ S	0 to 10 000 $\mu$ S
C	O	C	C	5 to 0 $\mu$ S	100 to 0 $\mu$ S	1 000 to 0 $\mu$ S	10 000 to 0 $\mu$ S
O	O	C	O	0 to 10 $\mu$ S	0 to 200 $\mu$ S	0 to 2 000 $\mu$ S	0 to 50 000 $\mu$ S
C	O	C	O	10 to 0 $\mu$ S	200 to 0 $\mu$ S	2 000 to 0 $\mu$ S	50 000 to 0 $\mu$ S
O	O	O	C	0 to 50 $\mu$ S	0 to 500 $\mu$ S	0 to 5 000 $\mu$ S	0 to 100 000 $\mu$ S
C	O	O	C	50 to 0 $\mu$ S	500 to 0 $\mu$ S	5 000 to 0 $\mu$ S	100 000 to 0 $\mu$ S
O	O	O	O	0 to 100 $\mu$ S	0 to 1 000 $\mu$ S	0 to 10 000 $\mu$ S	0 to 200 000 $\mu$ S
C	O	O	O	100 to 0 $\mu$ S	1 000 to 0 $\mu$ S	10 000 to 0 $\mu$ S	200 000 to 0 $\mu$ S
C = CLOSED		O = OPEN		Switch #4 inverts the output: OPEN = 4-20 mA, CLOSED = 20-4 mA			

## 6. Calibration

- All 2850 Conductivity/Resistivity Sensor Electronics are factory-calibrated for maximum out-of-the-box accuracy.
- The optional CR EasyCal feature allows calibration to be performed at the sensor.
- 4 to 20mA systems must be equipped with the CR EasyCal option for calibration.
- S<sup>3</sup>L systems may be calibrated at the sensor using the CR EasyCal option, or at the instrument such as +GF+ SIGNET model 8900.

### CR EasyCal circuit board

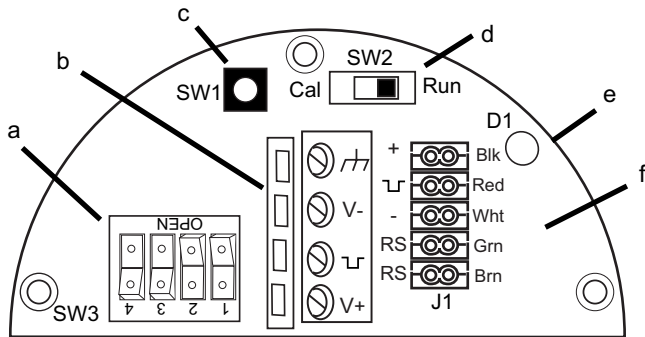

- 4-20 mA output range selection switches
- Power and 4 to 20mA or S<sup>3</sup>L™ output terminal block
- Push-button calibration (EasyCal option)
- S<sup>3</sup>L™ output interrupt (EasyCal option)
- LED indicator (EasyCal option)
- I/O terminal block to sensor electronics

### 6.1 EasyCal

CR EasyCal is an option which allows 1-point calibration to be performed local to the 2850 sensor system. During this procedure, if the measured value is within 10% of any of the 12 test values listed below, the 2850 will automatically recognize the test value and its output will be calibrated to that value.

#### Procedure:

- S<sup>3</sup>L™ systems ONLY: Place the RUN/CAL switch (SW2) in the CAL position. Wait at least 3 seconds before next step.
- 4-20 mA systems: The RUN/CAL switch is not used, and its position is of no consequence.

#### Note:

The first step (Reset) is recommended each time an electrode is replaced, but is **NOT** necessary upon initial installation or periodic calibration. In fact, for periodic calibration it is best for the electrode/sensor assembly to remain intact to minimize the possibility of moisture or other contamination entering the electrical interconnection area. The electrode/sensor connection must remain dry and clean at all times.

- Reset** the 2850 Sensor to factory calibration: With no power applied to the 2850, disconnect the electrode. Apply power, wait at least 3 seconds, then press and hold SW1 until the LED (D1) comes on steady then goes off again (approx. 10 seconds). When the LED goes off, release SW1; reset is complete.
- Place** the electrode/sensor assembly into the conductivity test solution appropriate to your operating range:
  - 146.93  $\mu$ S, 1408.8  $\mu$ S, 12856  $\mu$ S (per ASTM D1125-95)
  - 10  $\mu$ S, 100  $\mu$ S, 200  $\mu$ S, 500  $\mu$ S, 1000  $\mu$ S, 5000  $\mu$ S, 10,000  $\mu$ S, 50,000  $\mu$ S, 100,000  $\mu$ S (available from VWR Scientific)
- Allow at least 2 minutes for the electrode response to stabilize.
- Press** and hold SW1 for approximately 8 to 10 seconds. During this time, the LED will come on steady then go back off. (If the LED blinks several times rapidly, the calibration was not successful. See the troubleshooting section.)
  - For S<sup>3</sup>L™ systems, return RUN/CAL switch (SW2) to the RUN position.

Calibration is complete. Return the system to service.

**+GF+ SIGNET 2831**  
**Conductivity Certification Tool**

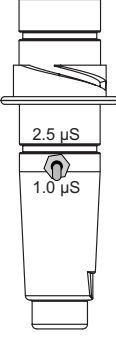

0.01 Cell Constant  
Simulates 1.0  $\mu$ S and 2.5  $\mu$ S,  $\pm$ 0.1  $\mu$ S

For use with +GF+ SIGNET 2850  
Conductivity/Resistivity  
Sensor Electronics.

If the 2850 includes  
the C/R EasyCal option,  
reset to factory calibration  
prior to verifying system accuracy.

If the system includes the  
8900 Multi-Parameter Controller,  
reset the appropriate channel  
to factory calibration and  
set TC to "Off".

## 7. Maintenance

- The 2850 requires no periodic maintenance.
- Coatings on the electrode may cause slow response or drift.  
Clean metallic surfaces with a mild detergent and a non-abrasive brush or cotton swab.

### 7.1 Troubleshooting

LED and Output Condition	Possible Causes	Suggested Solutions
<b>Current Out:</b> <b>LED off, current output is 22 mA</b>  <b>S<sup>3</sup>L™ out: "Check Sensor"</b>	<ul style="list-style-type: none"><li>• No electrode installed</li><li>• Bad/dirty contacts between electrode and 2850</li><li>• Electrode shorted</li></ul>	<ul style="list-style-type: none"><li>• Install electrode</li><li>• Check interconnection between electrode and 2850; clean contacts</li><li>• Clean all metallic surfaces of electrode</li></ul>
<b>During EasyCal, the LED blinks rapidly for 4 seconds.</b>	<ul style="list-style-type: none"><li>• Measured value of the test solution is outside the <math>\pm 10\%</math> tolerance.</li><li>• The electronics or the electrode is defective.</li></ul>	<ul style="list-style-type: none"><li>• Use fresh test solutions and restart the calibration.</li><li>• Replace the electronics or the electrode.</li></ul>
<b>After completing calibration procedure, the output values are inaccurate.</b>	<ul style="list-style-type: none"><li>• Insufficient time allowed for electrode stabilization during Cal procedure.</li><li>• Test solutions are contaminated.</li></ul>	<ul style="list-style-type: none"><li>• Recalibrate and wait at least 2 minutes after placing electrode in solution before pressing SW1.</li><li>• Use fresh test solutions and restart the calibration.</li></ul>

## 8. Ordering Information

Mfr. Part No.	Code	Description
3-2850-1	159 000 783	In-line Sensor Electronics
3-2850-2	159 000 784	In-line Sensor Electronics w/CR EasyCal
3-2850-3	159 000 785	Submersible Sensor Electronics, NPT
3-2850-4	159 000 857	Submersible Sensor Electronics, ISO

### 8.1 Parts and Accessories

Mfr. Part No.	Code	Description
3-2839-2	159 000 922	Cell 0.01, DryLoc, NPT
3-2839-2D	159 000 924	Cell 0.01, DryLoc, ISO
3-2840-2	159 000 787	Cell 0.1, DryLoc, NPT
3-2840-2D	159 000 789	Cell 0.1, DryLoc, ISO
3-2841-2	159 000 791	Cell 1.0, DryLoc, NPT
3-2841-2D	159 000 793	Cell 1.0, DryLoc, ISO
3-2842-2	159 000 795	Cell 10.0, DryLoc, NPT
3-2842-2D	159 000 797	Cell 10.0, DryLoc, ISO
3-9000.392-1	159 000 839	Liquid-tight connector kit, 1 set, 1/2 in. NPT
3-9000.392-2	159 000 841	Liquid-tight connector kit, 1 set, PG 13.5
3-2842.390	159 000 925	2842 replacement insulator, PEEK™ with FPM O-ring
3-2831	159 000 888	Conductivity Certification Tool
3-8050-1	159 000 753	Universal Mount Junction Box
3-8050-1CR	159 000 889	Universal Mount J-Box w/ CR Ranges
3-8050-2CR	159 000 802	Universal Mount J-Box w/ CR EasyCal
3-8052-1	159 000 755	3/4 in. NPT Mount Junction Box
3-8052-1CR	159 000 890	3/4 in. NPT Mount J-Box w/ CR Ranges
3-8052-2CR	159 000 803	3/4 in. NPT Mount J-Box w/ CR EasyCal

## +GF+ SIGNET

Signet Scientific Company, 3401 Aerojet Avenue, El Monte, CA 91731-2882 U.S.A. • Tel. (626) 571-2770 • Fax (626) 573-2057  
For Worldwide Sales and Service, visit our website: [www.gfsignet.com](http://www.gfsignet.com) • Or call (in the U.S.): (800) 854-4090

